

CP-850-24MT, absolute, 24 bit, multiturn

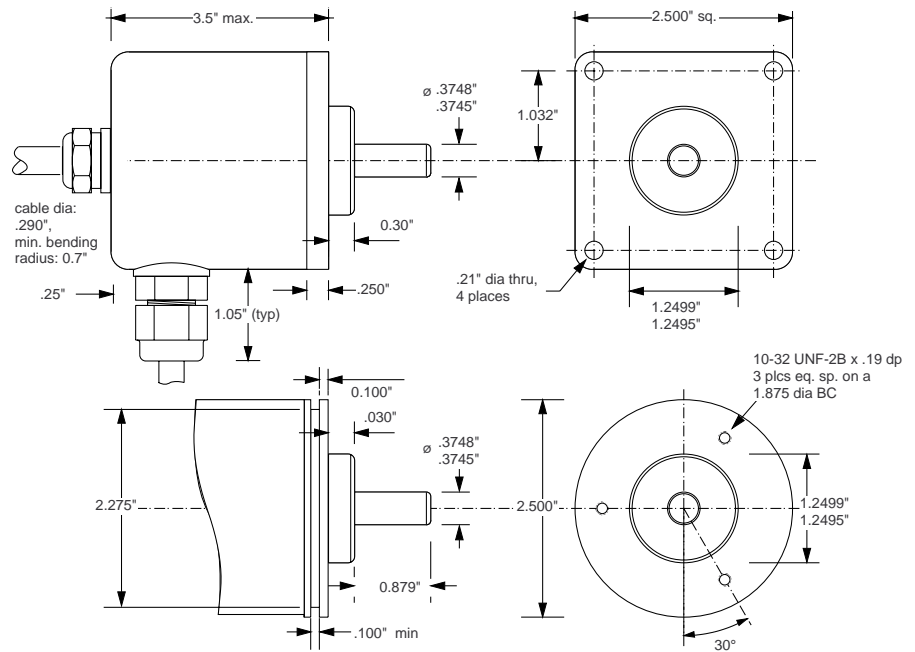

CP-850-24MT
Housed Shaft Encoder



CP-850-24MT, absolute, 24 bit, multiturn, hollow shaft



CP-950-24MT
Hollow Shaft Encoder

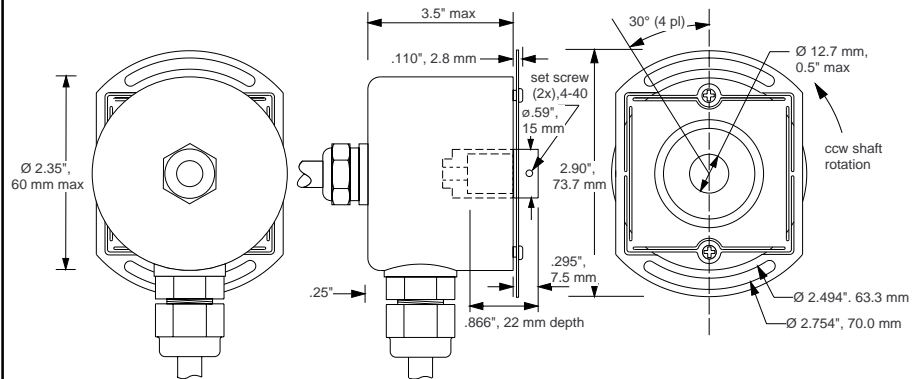

mechanical data

shaft diameter CP-850: .3745" / .3748"
 shaft diameter CP-950: 12.7 mm, 0.5" max
 shaft loading: 40 lbs axial, 35 lbs radial
 shaft runout: .0005" T.I.R.
 starting torque: 1.5 oz.in max @20°C
 shaft rotation: continuous, reversible
 bearings: ABEC 7, sealed
 shaft material: 416 stainless
 housing material: aluminum
 cover material: aluminum
 bearing life: manufacturer's specs
 moment of inertia CP-850: 4.1×10^{-4} oz.in.sec²
 moment of inertia CP-950: 6.3×10^{-4} oz.in.sec²
 weight: approx. 13 oz

environmental data

temperature: operating: -20°C to +90°C
 shock: 50 G's @ 11 ms
 vibration: 5-2,000 Hz @ 20 G's
 humidity: 98% without condensation
 protection: IP 64

CP-850/950-24MT, absolute, 24 bit, multiturn

Description:

The CP-850-24MT and CP-950-24MT are size 25, 24 bit absolute multiturn programmable encoders. The maximum resolution per turn is 12 bits (4096 positions) at 4096 turns, standard coding for the output is natural binary or Gray code. A reset input is provided to electronically set the position to zero. Information is formatted as serial (RS-232, RS-422, RS-485 or SSI) or as a parallel 24 bit word. Additionally, an analog 0-10 V or 4-20 mA is supplied as a separate output. This output can be customer-programmed over the RS-232 port for full scale over an arbitrary number of turns (PRG1) or fraction of turns (PRG2 & PRG3) and any number of counts per turn. In RS-485 mode, the encoder is addressable to allow operation of up to 32 units over a single I/O line.

Electrical Data:

code:	Gray or natural binary
power supply:	5, 11-17, or 11 - 30 Vdc @ 150 mA
output format:	parallel, serial and analog
freq. response:	25 RPS (1500 RPM) max
update rate:	10 ms
serial output:	9600 Baud standard, fiberoptic link optional
PLD:	MC34C87 or equivalent
PSR:	current source @ 100 mA/ch
PSK:	current sink @ 100 mA/ch
0 - 10 V analog:	10 mA sink/source
4 - 20 mA analog:	compliant to 30 V
status outputs:	5 mA sink, 10k pullup
all other inputs:	1 TTL load

Ordering Information:

CP-850 (or) -950-24MT-(1)-(2)-(3)-(4)-(5)-(6)-(7)-(8)

- (1): **Output Code**
 - GC = Gray code
 - BD = BCD
 - NB = natural binary
- (2): **Resolution**
 - 4096 = default
- (3): **Number of Turns**
 - up to 4096

For field programmable units replace (1)+(2)+(3) with:

 - PRG1 = program turns and counts/turn (whole turns)
 - PRG2 = program full-scale without a RS-232 terminal (fractional turns)
 - PRG3 = program full-scale and counts/turn (fractional turns)

Terminal emulation software is available on our website.
- (4): **Output Voltage**
 - AV = 0-10V
 - AC = 4-20 mA
 - AB = both
 - AX = none
- (5): **Serial Outputs**
 - S232 = RS-232
 - S422 = RS-422
 - S485 = RS-485
 - SSI = synchronous serial interface
 - SFO = fiberoptic data link

Parallel Outputs

 - PLD = 5 V differential linedriver
 - PSR = parallel source driver
 - PSK = parallel sink driver
- (6): **Power Supply**
 - 5 = 5Vdc supply
 - 12 = 11-17Vdc supply
 - 24 = 11-30Vdc supply
- (7): **Mounting**
 - S = servo mount
 - F = flange mount
- (8): **Connector/cable designator**
 - A = rear cable
 - B = side cable
 - C = rear connector
 - D = side connector

RS 485 Operation:

The encoder may be field programmed through either the RS-232 or 485 port to set the individual addresses and other parameters (PRG1, PRG3). Only one unit should be connected to the RS-485 bus during programming.

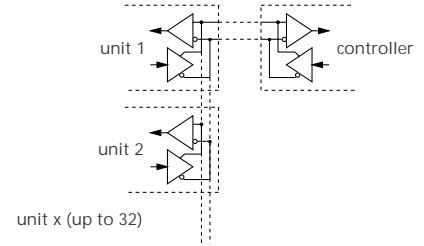

Serial Format:

RS-422 and RS-232 serial data is sent out every 10 ms, default data format shown below. RS-485 serial data is sent out on request with a different format. The RS-485 option includes RS-232 drivers. Therefore, for applications requiring RS-232 interface with data sent out on request, order RS-485.

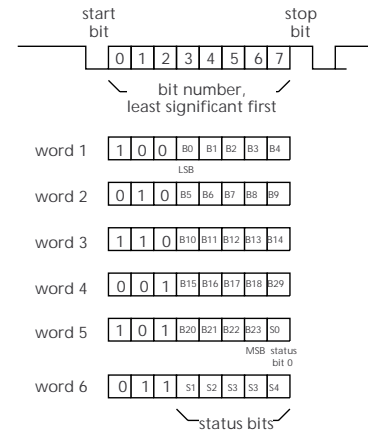

The BD option (binary coded decimal) consists of a string of ASCII characters followed by a <CR>, with an asterisk (*) indicating a low status line (error condition).

The status bits S₁ through S₄ have arbitrary assignments and may be customer-defined. Status bit S₀ is fixed and has the same meaning as the discrete status line, high: data valid, low: error condition.

SSI Interface:

In quiescent mode, both the clock and data outputs are high. On the first falling edge of the clock, the actual encoder position information is memorized and bit 23 (MSB) will be available. On the next rising edge, subsequent bits will be shifted out, starting with bit 22. After transfer of all 24 bits, the data output stays low. After the clock remains high for t₃ seconds, the encoder is ready for a new data transfer.

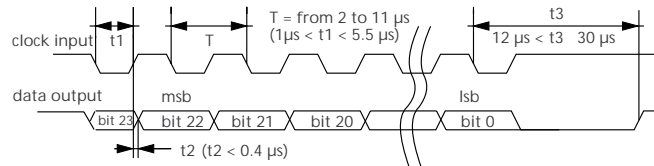
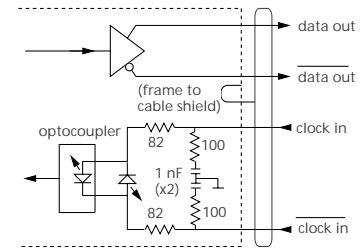

Functions:

signal name:	function:
• data lines 0 through 23	parallel data
• reset/prog line	resets output to zero, active high
• direction line	high: increase count CCW
• status line	high: data valid, low: error condition (optional)
• data ready line	high: data valid for binary and BCD outputs (optional)
• RS-232 in & out	serial output of data
• RS-422 & RS-422 inv.	allows programming of certain models from a "dumb" terminal, consult factory
• RS-485 & RS-485 inv.	serial output of data
• Vout, V out ground	individual addressing & output of data
• I out, I out return	Analog voltage output (full-scale programmable)
	Analog current output (full-scale programmable)

Full-scale programming of the analog outputs (PRG2):

The reset line and direction input line are used to program the analog outputs. The reset line is normally tied to ground or left "floating", the direction line is either tied to the positive power supply or to ground, dependent on preferred counting direction. The programming sequence is as follows:
 1/ at "zero" turns, connect the reset line to the positive power supply. The encoder is now in "program" mode.
 2/ turn the shaft the desired number of revolutions
 3/ change the logic level of the direction input line. If it was tied to ground, connect to the positive power supply. If it was tied to the positive power supply, connect to ground. This signals the encoder that this position is the end.
 4/ Connect the reset line to ground and connect the direction line as required for the chosen counting direction. The encoder output should now be 10 V/20 mA. It is very important not to change the state of the direction input during a "normal" reset as this will re-program the full-scale setting of the unit.

programming instructions

Description:

This instruction describes a standard configuration of the CP-850-24MT model series.

Features of this unit are the 24 bits of position data, available from an RS-232 compatible serial output (serial format described below) and a 4-20 mA, 0-10 V full scale analog output.

The CP-850-24MT is an all-electronic multiturn encoder. Because it uses an electronic counter rather than mechanical gears to keep track of the shaft position during power down, it contains a Ni-Cad battery to keep track of and maintain the position information.

The battery may be discharged at the time of installation and it will take about 18 hours of the encoder to be connected to its normal power supply to reach a full charge. The encoder is immediately functional, though, as soon as installed. The battery will last beyond 1000 charge/discharge cycles.

The encoder will be fully functional without power for at least 500 hours. Maximum shaft speed is 1,200 RPM with power applied and 150 RPM without.

Control outputs

When the unit is first turned on, it goes through a self diagnostic routine. If the encoder determines that the battery voltage was too low at power up, it will reset itself to "zero" position. At the same time, it will send the status bit low (S_0 , bit 7 of word 5), indicating a low battery condition. The status bit will remain low until the encoder is reset (or the power is cycled of and then on again) and the battery becomes charged again.

The status bit can be used as an indication that the system needs to be re-initialized by resetting the encoder at the appropriate mechanical position. If the status bit continues to go low, it means that the internal batteries have not been fully charged yet and that if the power is disrupted, information will be lost.

The status bit is also available as a discrete line.

Control inputs

There are two basic control lines:

- 1) RESET/PROG and
- 2) DIRECTION.

These lines must be tied to ground (logic "0" or LO) or to any voltage equal or greater than 5 Vdc (logic "1" or HIGH). If these lines are not properly terminated, erratic operation of the encoder may result. The RESET/PROG line may be left "floating", as a pull-down internal resistor is supplied.

RESET/PROG must be LO for normal operation. Sending this line HI causes a reset to occur and the analog output goes to 0.00 Vdc (4 mA for the current output) and the digital serial/parallel outputs go to \$000000.

DIRECTION, when tied LO causes the output to increase with CW shaft rotation (as seen from the shaft end), HI will cause the output to increase with CCW shaft rotation.

Programming instructions:

The encoder is programmable so the user may specify the number of "turns" parameter and the "counts per turn" parameter as follows:

Terminate the DIRECTION control input (HI or LO) and connect the RESET/PROG control to the supply voltage (or any voltage greater than 4.5 Vdc).

Connect RS-232 IN to pin 2, RS-232 OUT to pin 3 and GROUND to pin 7 of an RS-232 DB 25 pin connector. The DB-25 connector connects to a "dumb" terminal or a PC in terminal emulation mode (Terminal emulation software is available on our website at www.opticalencoder.com).

When power is applied (and assuming everything is hooked up properly) the terminal display or computer monitor will display similar to the following:

```
@      C=4096  T=500  N+
```

@ is the symbol used to identify that the encoder is in "program" mode

T is the number of turns parameter (valid data: 1-4096)

C is the counts per turn parameter (valid data: 1-4096)

N is the parallel/serial output code parameter (valid data: N, G, B)

+ direction parameter (valid data: <+> = CW, <-> = CCW for increasing count)

The following is a list of keystrokes and their function. The keys next to the letter T were chosen to affect the number of turns parameter and the keys next to the C key were selected to affect the counts per turn parameter:

```
Q      decrease turns by 100
W      decrease turns by 10
E      decrease turns by 1
R      increase turns by 1
T      increase turns by 10
Y      increase turns by 100
```

```
Z      decrease counts by 100
X      decrease counts by 10
C      decrease counts by 1
V      increase counts by 1
B      increase counts by 10
N      increase counts by 100
```

```
D      changes direction parameter
P      increments output code parameter
<esc> restore original parameters
```

Each command sent is displayed immediately after the "@" symbol. After setting the parameters bring the RESET/PROG control input low.

programming instructions, wiring

Position data output format:

The output code parameter establishes the output code and format of the position data for both parallel and serial output configurations:

output code parameter	serial	parallel
N	NB (natural binary)	24 bit NB
G	GC (Gray code)	24 bit GC
B	ASCII	6 digits of BCD

Serial data format:

Format: 6 words of 1 start, 8 data (D0 thru D7), 1 stop bit, no parity (8N1). Transmitted every 9 ms at 9,600 Baud. Status is D7 of word 5. LSB is sent first, right after the start bit:

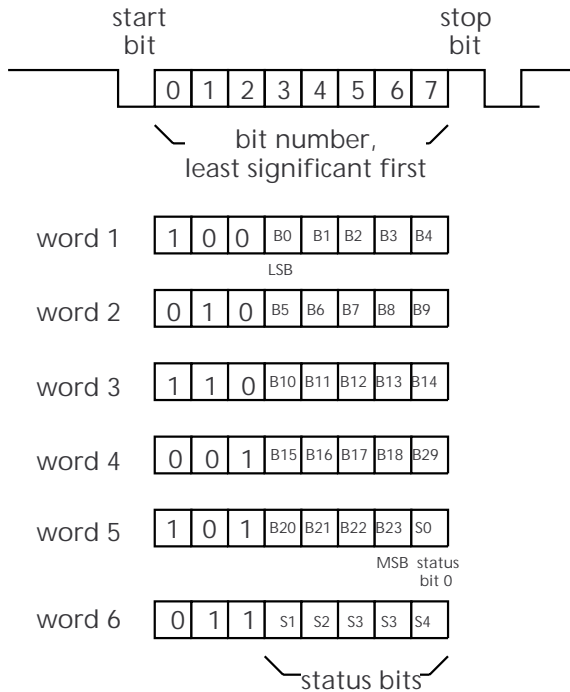

ASCII format: string of 10 ASCII characters transmitted every 9 ms at 9.600 Baud (1N8). The first 8 characters are ASCII numerals representing position. The next character is status: either a blank (status = HI) or an asterisk (status = LO), followed by a carriage return <cr>. For example, a 10 turn unit with 500 counts per turn at full scale with a low battery would display:

00004999* <cr>

Output wiring:

Connections to the encoder is made via a Belden #8335 cable. below is the default wire color assignment:

signal	PCB pin (internal)	color
+ 11 to 17 Vdc power ground	P1-1 P1-2	white with grey stripe gray with white stripe
direction status (option)	P1-10 P1-5	green with white stripe white with green stripe
reset/prog	P1-4	brown with white stripe
chassis	solder lug	shield
RS-232 out	P1-6	white with orange stripe
RS-232 in	P1-8	orange with white stripe
I out (Vout)		white with blue stripe
I out return (Vout ground)		blue with white stripe

RS-232 PC serial port connection:

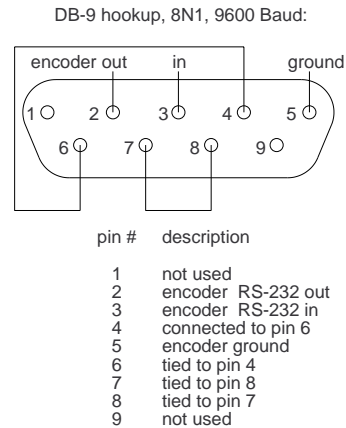

Protocols:

Please consult factory. Many different protocols are available with custom configurations available at a nominal charge.